

Business Solutions

BULK HANDLING EQUIPMENT

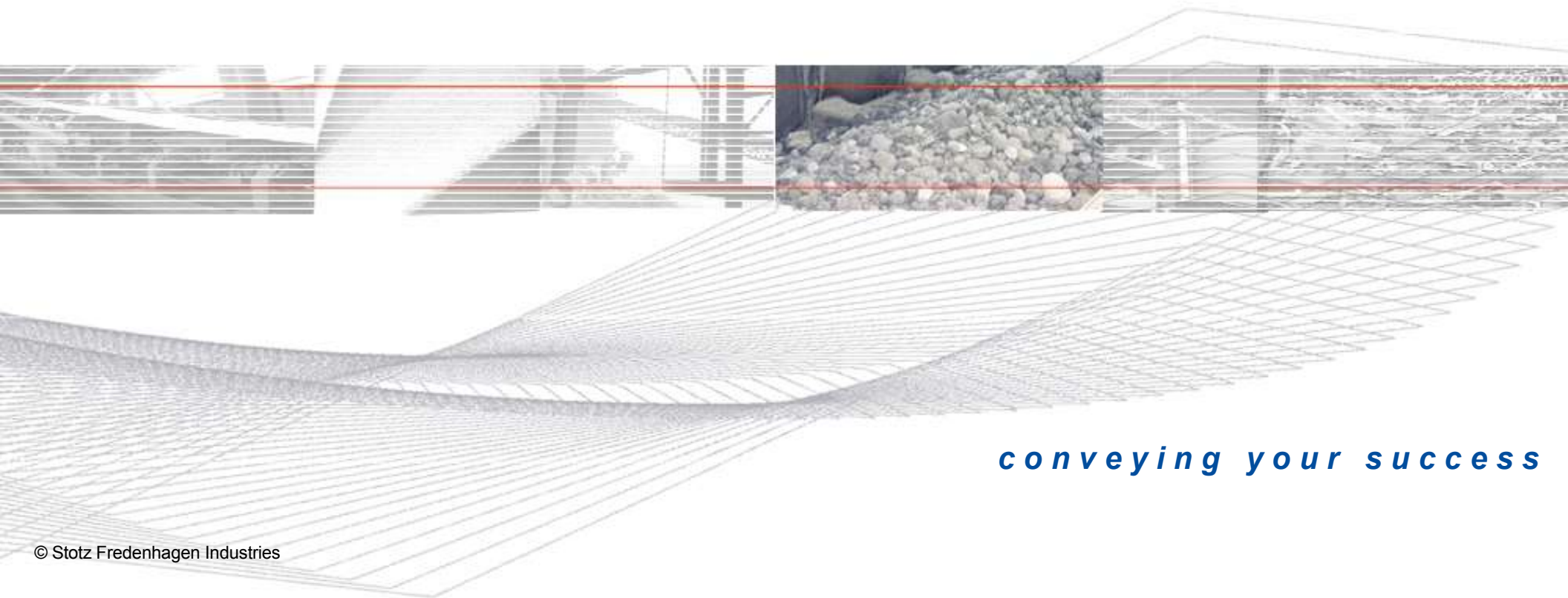

conveying your success

Business Solutions > Bulk Handling Equipment

OVERVIEW

- **Industries**
- **Products**
- **Services**



Business Solutions > Bulk Handling Equipment > Industries

INDUSTRIES

CEMENT & MINING



POWER & ENERGY



AGRICULTURAL & FOOD



Business Solutions > Bulk Handling Equipment > Industries

INDUSTRIES

CHEMICAL INDUSTRY

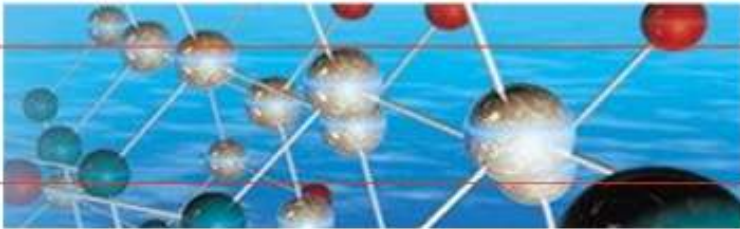

DISPOSAL & RECYCLING



Business Solutions > Bulk Handling Equipment > Products

PRODUCTS

- Belt Conveyors
- Pan Apron Conveyors
- Bucket Elevators
- Drag Chain Conveyors
- Screw Conveyors
- Hinged Steel Belts

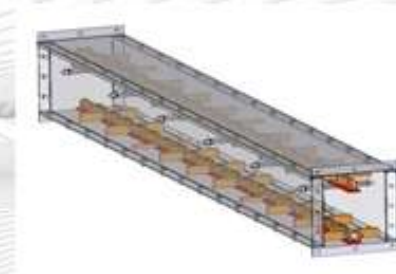

Business Solutions > Bulk Handling Equipment > Products

BELT CONVEYOR SYSTEMS

Highlights:

- Low cost
- Low maintenance
- Long service life
- Smooth handling
- Low noise

Applications:

- Feeding (kilns, dumping lots ...)
- Discharging (bins, silos)
- Collection (mining, material extraction & processing, quarries, food/pharma/chemicals, maritime ports)

Technologies:

- Stationary and movable
- Widths upto 2000 mm
- Throughput up to 2000 tph
- Large range of belt variants
- Special designs (reaction belts, Flexowell belts)



Business Solutions > Bulk Handling Equipment > Products

PAN APRON CONVEYORS

Highlights:

- Flexible track arrangements
- Suitable for extreme conditions (hot or cold material transport etc.)
- No material droppings

Applications:

- All handling tasks where belt conveyors cannot be used due to high temperatures, steep inclines/declines and/or adverse conditions
- Materials extraction & processing
- Transport of rough & high granulometry materials

Technologies:

- Pan/apron/deep bucket
- Possibility of very steep inclines by in-built back-stop walls
- Heavy duty designs for bin discharge or crusher feeding scenarios

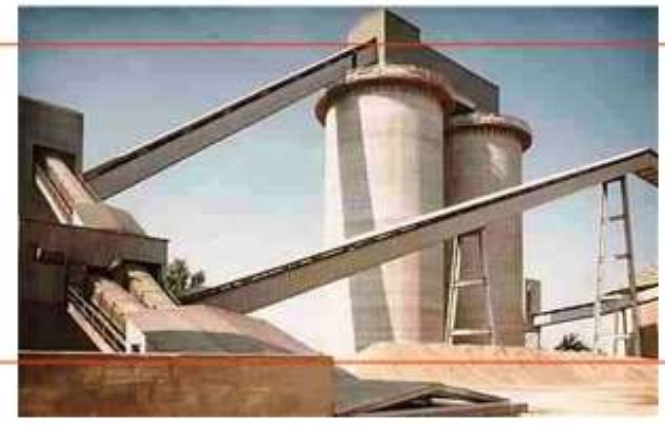

Business Solutions > Bulk Handling Equipment > Products

BUCKET ELEVATORS

Highlights:

- Very long service life, low maintenance and clean operation in case of belt elevators, due to zero lubrication
- Possibility of pivoting bucket design allowing combined vertical and horizontal transport, without the need of material reloading, and offering various distribution methods
- Self-supporting designs

Applications:

- Vertical and/or horizontal transport of dusty, close grain, powdery, flaky or lump size bulk materials
- Materials processing
- Food/pharma/chemicals

Technologies:

- Belt traction (outside hot zones) or chain traction
- Many different designs depending on operation mode and material sensitivity, grain size and flow properties



Business Solutions > Bulk Handling Equipment > Products

DRAG CHAIN CONVEYORS

Highlights:

- Maximum hygiene and environmental friendliness due to dust-proof design
- Suitable also for hot / abrasive / poisonous or smelly materials
- Low space requirements
- Low maintenance

Applications:

- Food / pharma / chemicals
- Material processing
- Outdoor loading facilities
- Direct discharge from bins, silos, etc.

Technologies:

- Availability of special designs (gas and / or pressure-proof)
- Horizontal and inclined designs (or combinations)
- Any desired number of discharge points along the track

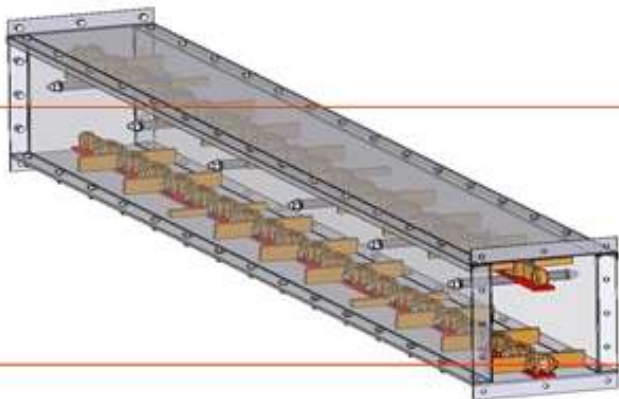

Business Solutions > Bulk Handling Equipment > Products

SCREW CONVEYORS

Highlights:

- Low cost
- Low maintenance
- ILw space requirements

Applications:

- Fertilizer production
- Chemical industry
- Anode production
- Paper mills

Technologies:

- Transport screws
- Mixing screws
- Granulating screws
- Cooling screws
- Special steel designs available

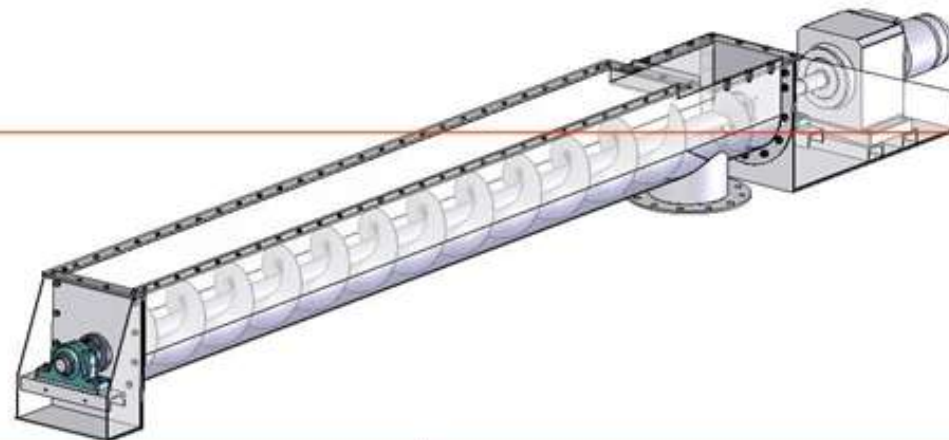

Business Solutions > Bulk Handling Equipment > Products

DISPOSAL & RECYCLING

Applications:

- Sheetmetal working (press shops)
- Waste incineration
- Waste sorting
- Waste paper recycling
- Production scrap collection

Technologies:

- Hinged Steel Belts
- Slat Conveyors
- Belt Conveyors
- Drag Chain Conveyors
- Screw Conveyors



Business Solutions > Bulk Handling Equipment > Products
ANCILLARY EQUIPMENT & STEELWORK

- Gravity equipment including all guiding and obturation devices
- Distribution facilities
- Chutes & connectors
- Gantries (open / enclosed)
- Bins & silos
- Skip conveyors
- Feed proportioning devices
- Loading equipment for bulk or bagged materials (universal or alternating)
- Strippers (stationary, movable, rotating)
- Scraping equipment



Business Solutions > Bulk Handling Equipment > Services

SERVICES

- Planning & Design

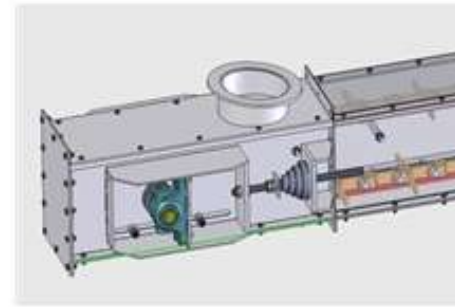
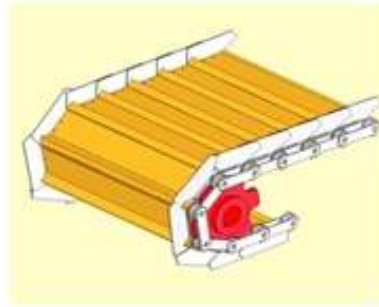

- On-Site Installation & Commissioning



- After-Market Services



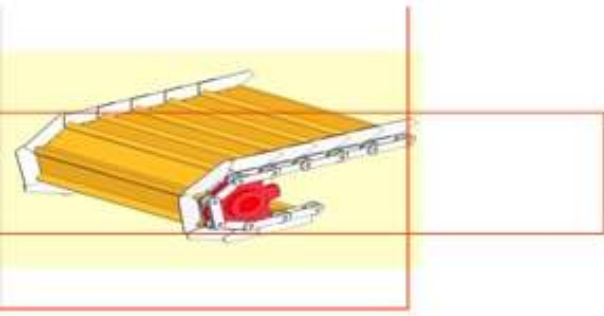

Business Solutions > Bulk Handling Equipment

CONTACT

QUANTUM DYNAMICS (PVT.) LIMITED

Airport Road, Sadiqabad, District Rahimyarkhan
Punjab, Pakistan
Tel.: +92 068 5010071-72
Fax: +92 307 2741001

info@qdpl.com.pk
www.qdpl.com.pk

conveying your success